

Lubrication schedule for Railcar Trailer Hitch 80800 / 80800-Z

1. Lubrication schedule for the initial operation and maintenance of the base plate of Railcar Trailer Hitch 80800 / 80800-Z

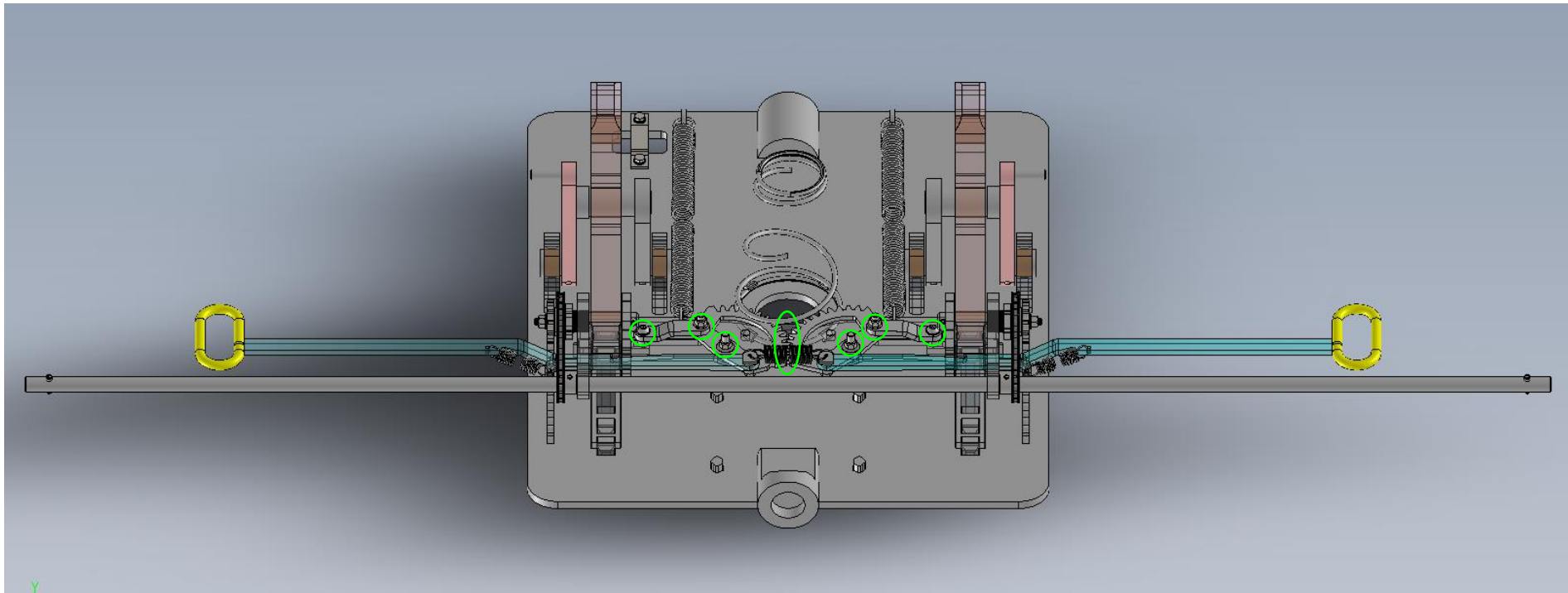

- The marked areas are to be sprayed with spray oil during initial operation and maintenance. Following this, lubricating oil is suggested. > see table on page 4

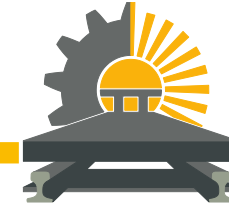

Lubrication schedule for Railcar Trailer Hitch 80800 / 80800-Z

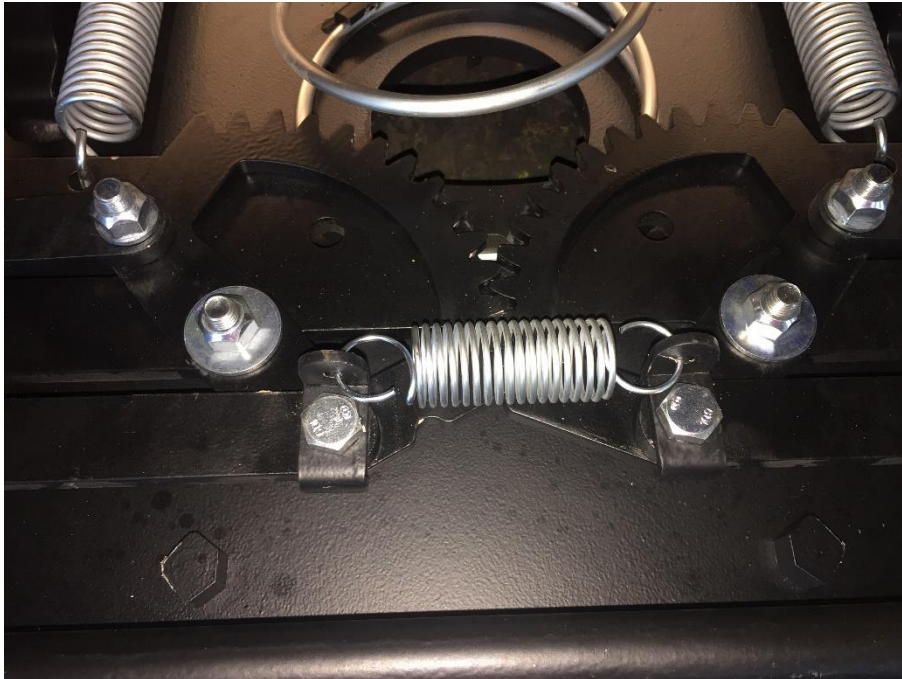

Chains may be sprayed with a chain spray. CAUTION: DO NOT APPLY GREASE !

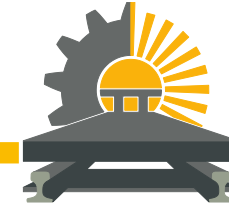

Lubrication schedule for Railcar Trailer Hitch 80800 / 80800-Z

2. Lubrication schedule for the initial operation and maintenance of the base plate of Railcar Trailer Hitch 80800 / 80800-Z

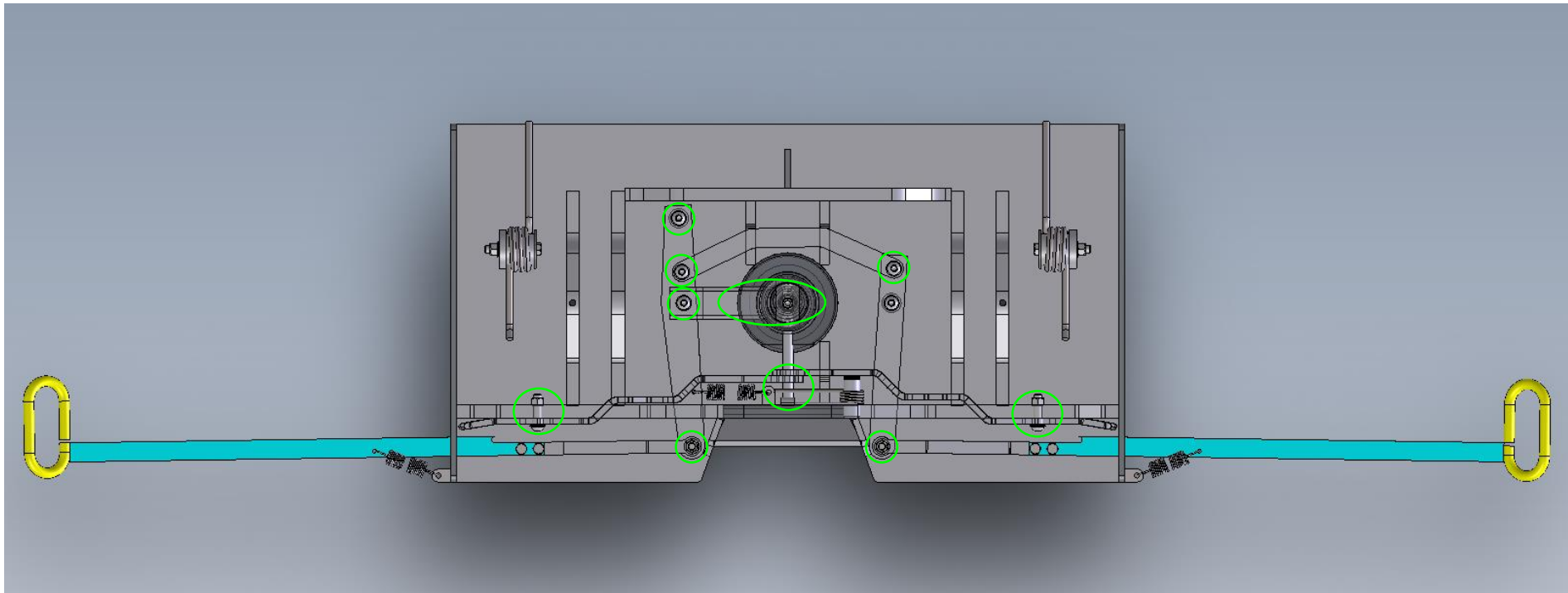

- The marked areas are to be sprayed with spray oil during initial operation and maintenance. Following this, lubricating oil is suggested. > see table on page 4

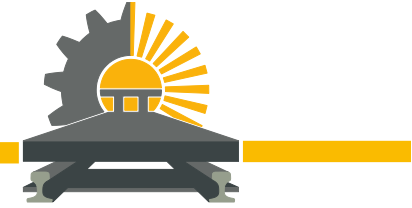

Lubrication schedule for Railcar Trailer Hitch 80800 / 80800-Z

Recommended lubricants:

- Tunap Tungrease CS-2 (is no longer produced new)
 - Replacement with Tunap Tungrease CP-2/50
- WEM 40
- L-AN 68 lubrication oil